

Descripción	Código	Medidas / Color	Emb.
-------------	--------	-----------------	------

Soporte número 3 de pincho.

7006-1

ZINCADO

500

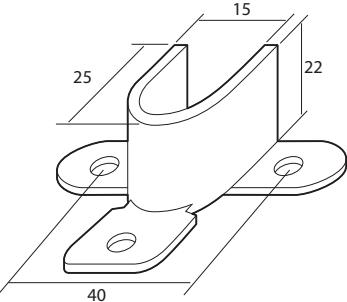

Soporte número 3 de orejas.

7006-2

ZINCADO

500

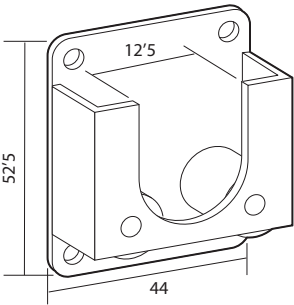

Soporte de roldanas.

7006-3

ZINCADO

150

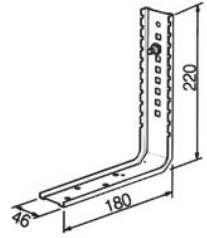

Escuadra para cápsula doble con nudo.

7006-28

ZINCADO

50

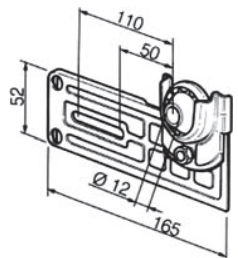

Escuadra para soporte cápsula doble con nudo con rodamiento 42 mm.

7006-80

ZINCADO

50

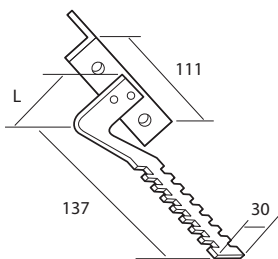

Lado largo soporte Cataluña F.

7006-47

L= 130 con PLETINA

50

7006-48

L= 130 sin PLETINA

50

7006-49

L= 150 con PLETINA

25

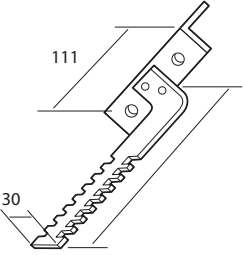
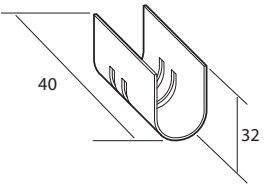
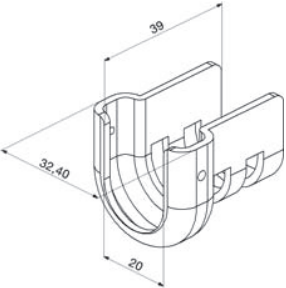
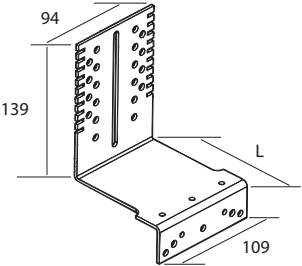
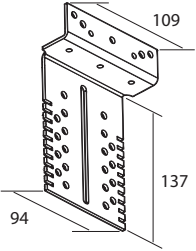
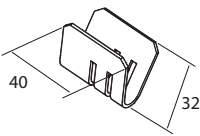

	Descripción	Código	Medidas / Color	Emb.
	Lado corto soporte Cataluña F.	7006-45	Con PLETINA	50
		7006-46	Sin PLETINA	50
	U para soporte Cataluña F.	7006-27	U NORMAL	200
	U para soporte Cataluña F.	7006-30	U para RODAMIENTO	200
	Lado largo soporte Cataluña especial.	7006-37	L= 110 con ALETA	25
		7006-40	L= 110 sin ALETA	25
		7006-38	L= 130 con ALETA	25
		7006-41	L= 130 sin ALETA	25
	Lado corto soporte Cataluña especial.	7006-43	Con ALETA	50
		7006-44	Sin ALETA	50
	U Soporte Cataluña especial.	7006-50	U NORMAL	200

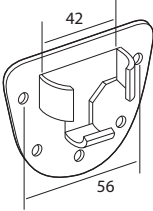
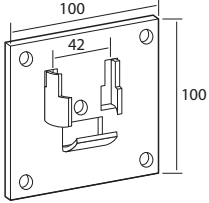
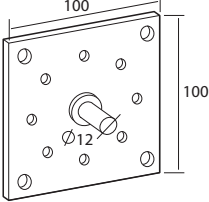
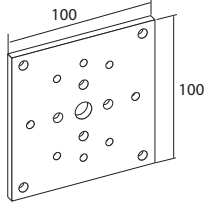
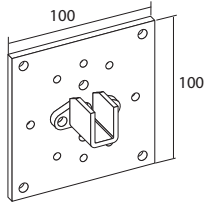
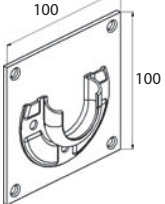
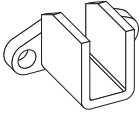
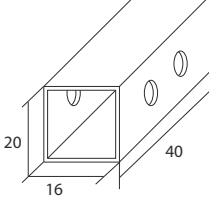

	Descripción	Código	Medidas / Color	Emb.
	Soporte de obra para rodamiento de Ø 42 mm.	7006-13	ZINCADO	100
	Soporte para rodamiento de Ø 42 mm. con placa de 100 x 100 mm. Especial testero de 250 y 300 - 45°	7006-14	ZINCADO	100
	Soporte con espiga de Ø 12 mm. y placa de 100 x 100 mm. Especial testero de 250 y 300 - 45°	7006-15	ZINCADO	100
	Placa de 100 x 100 mm. para motor.	7006-59	ZINCADO	100
	Placa de 100 x 100 mm. para muelle de compensación y tiro directo.	7006-58	U = 13 mm. ZINCADO	100
		7006-68	U = 16 mm. ZINCADO	100
	Placa 100 x 100 x 3 mm. Soporte para rodamiento Ø 42 mm.	7006-107	BICROMATADO	50
	Soporte de U para muelle de compensación y tiro directo.	7006-60	U = 13 mm. ZINCADO	100
		7006-67	U = 16 mm. ZINCADO	100
	Adaptador cuadradillo 20 x 16 mm. para testero con tetón del muelle de compensación y tiro directo.	7006-69	ZINCADO	100



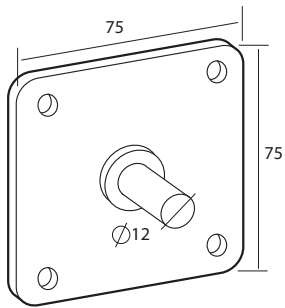

Soporte con espiga de Ø 12 mm. y placa de 75 x 75 mm. para obra.

7006-16

ZINCADO

100

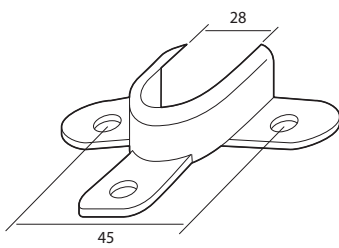

Soporte para rodamiento de Ø 28 mm.

7006-17

ZINCADO

500

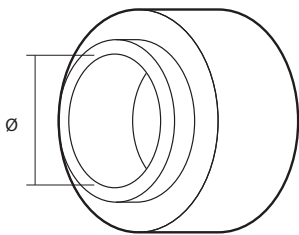

Rodamiento a bolas Ø 28 mm.

7006-19

Ø 10 NYLON

400

7006-20

Ø 10 METÁLICO

400

7006-21

Ø 12 NYLON

400

7006-22

Ø 12 METÁLICO

400

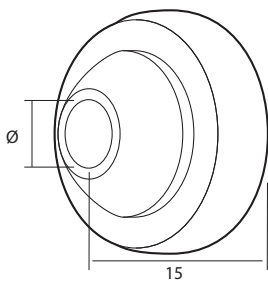

Rodamiento a bolas fuerte Ø 42 mm.

7006-23

Ø 10 METÁLICO

100

7006-24

Ø 12 NYLON

100

7006-25

Ø 12 METÁLICO

100

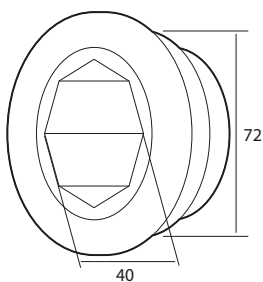

Rodamiento especial nylon Ø 72 mm. para acoplar en testero pasante.

7006-26

NYLON

100

